

April 2016

## GENERAL DESCRIPTION

The HI-8200H family are quad analog CMOS switches fabricated with Silicon-on-Insulator (SOI) technology for latch-up free operation and maximum switch isolation. They are optimized for use in high temperature avionics applications. The devices are capable of operating at extended temperature ranges of -55°C to 175°C for plastic packages and -55°C to 200°C for the ceramic CERDIP-16 package. High voltage gate drive is entirely created on-chip enabling +/-12V switching range from a single 3.3V or 5V supply. These switches are ideally suited for applications demanding low switch leakage when the power pins are 0V.

At 25°C and with VDD from 3.0V to 5.5V, the switch resistance (RON) is typically 8Ω. RON is independent of VDD. In a switching range of -5V to +5V, the maximum deviation of RON from flat is less than 5%.

These switches conduct equally well in either direction. Power down and Off state leakages are less than 10nA maximum. Charge injection is less than 10pC. Switching times are typically 180ns to the On state and 60ns to the Off state. The on-board charge pump allows an On/Off cycle time of 5KHz for all four switches simultaneously before the switching range becomes restricted.

The HI-8200H provides four each normally open switches when the switch control inputs are low. The HI-8201H provides four each normally closed switches when the switch control inputs are low. The HI-8202H provides a combination of two normally closed and two normally open switches.

## APPLICATIONS

- Down-hole drilling and oil exploration
- High temperature avionics
- Data bus isolation
- Sample-and-Hold circuits
- Test Equipment
- Communications Systems

## FEATURES

- Extended Temperature Ranges
  - -55°C to 175°C (plastic packages)
  - -55°C to 200°C (ceramic CERDIP-16 package)
- CMOS analog switches with up to +/-12V switching range from a single 3.3V or 5V supply
- Low RON: 10Ω max at 25°C
- Robust CMOS Silicon-on-Insulator (SOI) technology
- Switch nodes are open-circuit when chip is powered down
- SOI switch isolation with 1nA typical Off leakage
- ESD protection > 4KV HBM
- Fast switching time with break-before-make
- Low power

## PIN CONFIGURATIONS (Top Views)

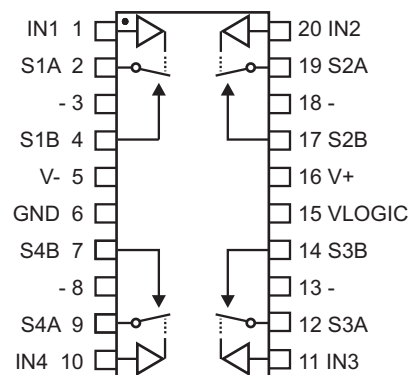

HI-8200PSHF  
20-Pin TSSOP package

PRODUCT OPTIONS								
PART TYPE	IN1	Switch 1	IN2	Switch 2	IN3	Switch 3	IN4	Switch 4
HI-8200H	0	Open	0	Open	0	Open	0	Open
	1	Closed	1	Closed	1	Closed	1	Closed
HI-8201H	0	Closed	0	Closed	0	Closed	0	Closed
	1	Open	1	Open	1	Open	1	Open
HI-8202H	0	Open	0	Closed	0	Closed	0	Open
	1	Closed	1	Open	1	Open	1	Closed

## PIN DESCRIPTIONS

SIGNAL	FUNCTION	DESCRIPTION
IN1	Logic Input	HI-8200H and HI-8202H are normally Open when input Low
S1A	Switch Node	Switch 1 Node
S1B	Switch Node	Switch 1 Node
V-	CAP -	Bulk storage capacitor. Add 0.1uF ceramic capacitor to GND. (20V or higher).
GND	Supply	Reference Ground
S4B	Switch Node	Switch 4 Node
S4A	Switch Node	Switch 4 Node
IN4	Logic Input	HI-8200H and HI-8202H are normally Open when input Low
IN3	Logic Input	HI-8201H and HI-8202H are normally Closed when input Low
S3A	Switch Node	Switch 3 Node
S3B	Switch Node	Switch 3 Node
VLOGIC	Supply	3.3V or 5.0V Logic supply
V+	CAP +	Bulk storage capacitor. Add 0.1uF ceramic capacitor to GND. (20V or higher).
S2B	Switch Node	Switch 2 Node
S2A	Switch Node	Switch 2 Node
IN2	Logic input	HI-8201H and HI-8202H are normally Closed when input Low

**NOTE:** V+ and V- pins are **only** to be used for connection of bulk storage capacitors and **MUST NOT** be loaded.

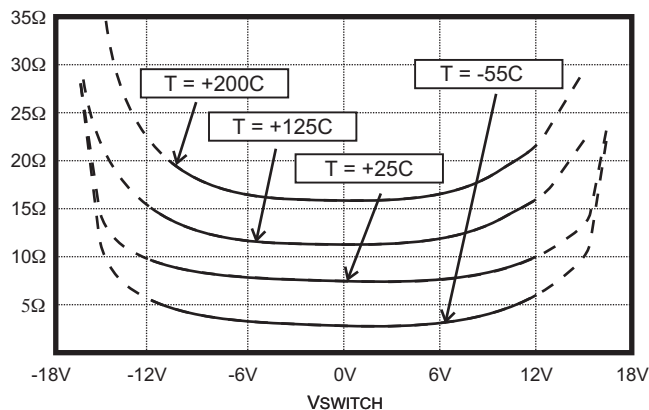

Typical RON as a function of VSWITCH and Temperature (10mA switch current, VSUPPLY = +3.3V)

## ABSOLUTE MAXIMUM RATINGS

(Voltages referenced to GND = 0V)

Supply Voltage, V <sub>LOGIC</sub> .....7.0V	Operating Temperature Range: (Plastic) ..... -55°C to +175°C (Ceramic) ..... -55°C to +200°C
Switch Current (either direction, DC): .....20mA	
Peak Switch Current (1 ms pulse, 10% duty cycle max.).....100mA	Storage Temperature Range: .....-65°C to +150°C
Digital Input Voltage (IN1-4):.....-0.3V to V <sub>LOGIC</sub> + 0.3V	
Reflow Soldering Temperature: ..... +260°C Max.	

NOTE: Stresses above those listed under "Absolute Maximum Ratings" may cause permanent damage to the device. These are stress ratings only. Functional operation of the device at these or any other conditions above those indicated in the operational sections of the specifications is not implied. Exposure to absolute maximum rating conditions for extended periods may affect device reliability.

## ELECTRICAL CHARACTERISTICS

V<sub>LOGIC</sub> = 3.3V or 5.0V, GND = 0V. Operating temperature range (unless otherwise noted).

PARAMETER	SYMBOL	CONDITIONS	FIGURE	MIN	TYP	MAX	UNIT
<b>SWITCH PARAMETERS</b>							
Switch Resistance, 25°C, 10mA	R <sub>ON</sub>	12V > V <sub>s</sub> > -12V	1	6	8	10	Ω
Leakage - (open circuit and power down)	I <sub>SWLEAK</sub>	Switch voltage ± 12V, 125°C Switch voltage ± 12V, 200°C	2			10 2	nA μA
Leakage - (open circuit and power on)	I <sub>SWLEAKp</sub>	Switch voltage ± 12V, 125°C Switch voltage ± 12V, 200°C				100 4	nA μA
<b>LOGIC INPUTS</b>							
Input High Voltage	V <sub>IH</sub>			75%			V
Input Low Voltage	V <sub>IL</sub>					25%	V
Input Current	I <sub>IH</sub>  I <sub>IL</sub>	80K Ohm pulldown V <sub>Logic</sub> = 3.3V V <sub>Logic</sub> = 5.0V 125°C 200°C			45 65	0.5 2	μA μA μA
<b>SUPPLY</b>							
V <sub>Logic</sub> Operating Range	V <sub>DD</sub>			3.0		5.5	V
V <sub>Logic</sub> Operating Current	I <sub>DD</sub>	inputs static V <sub>Logic</sub> = 3.3V V <sub>Logic</sub> = 5.0V				1.0 2.5	mA mA
<b>DYNAMIC PARAMETERS</b>							
Max Vin On/Off cycling	f <sub>cycle</sub>	any load				5	Khz
Turn On Time	T <sub>ON</sub>		3		180	250	ns
Turn Off time	T <sub>OFF</sub>		3		80	150	ns
Break-Before-Make Time	T <sub>D</sub>		4	40	80		ns
Charge Injection	Q	V <sub>s</sub> =0V, R <sub>s</sub> =0Ω, 25°C	5		-20		pC
Off Isolation	R <sub>R</sub>	f = 1 MHz, 25°C	6		65		dB
Crosstalk	C <sub>R</sub>	f = 1 MHz, 25°C	7		90		dB
Capacitance	C <sub>OFF</sub> C <sub>ON</sub>	Switch Off, 25°C Switch On, 25°C	8 9		15 60		pF pF
Charge Pump Power On	T <sub>von</sub>	V <sub>+</sub> and V <sub>-</sub> = +/-14.5V V <sub>Logic</sub> = 5.0V	10	10			ms

TEST CIRCUITS

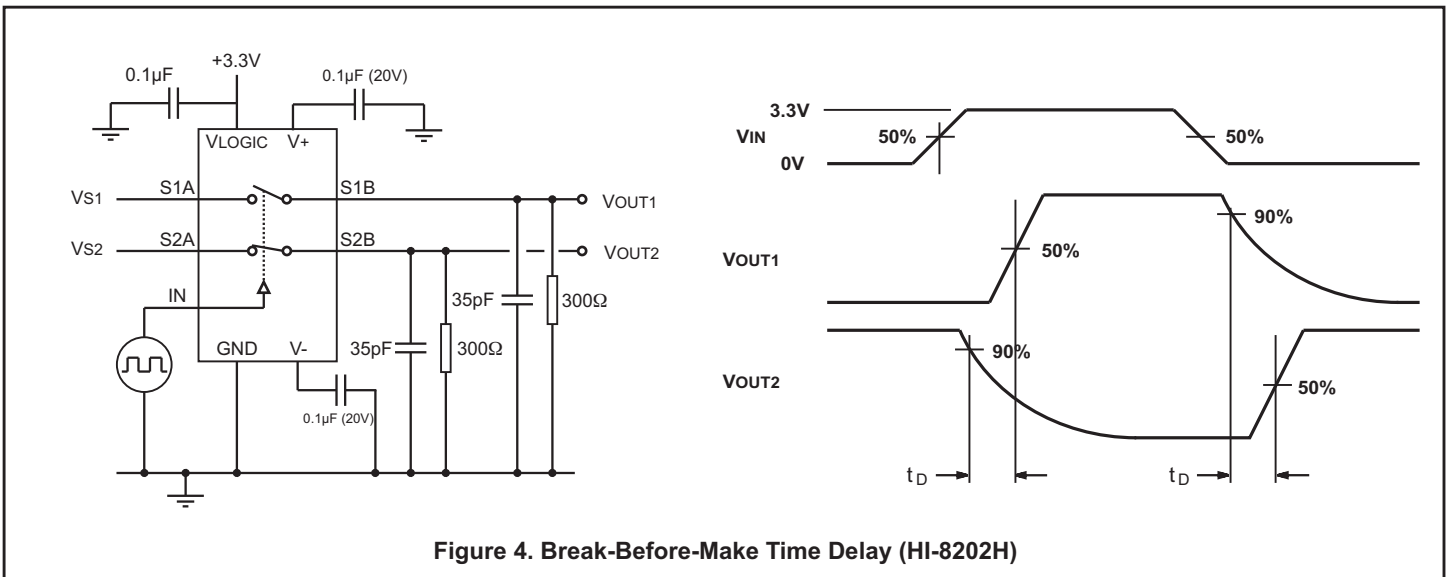
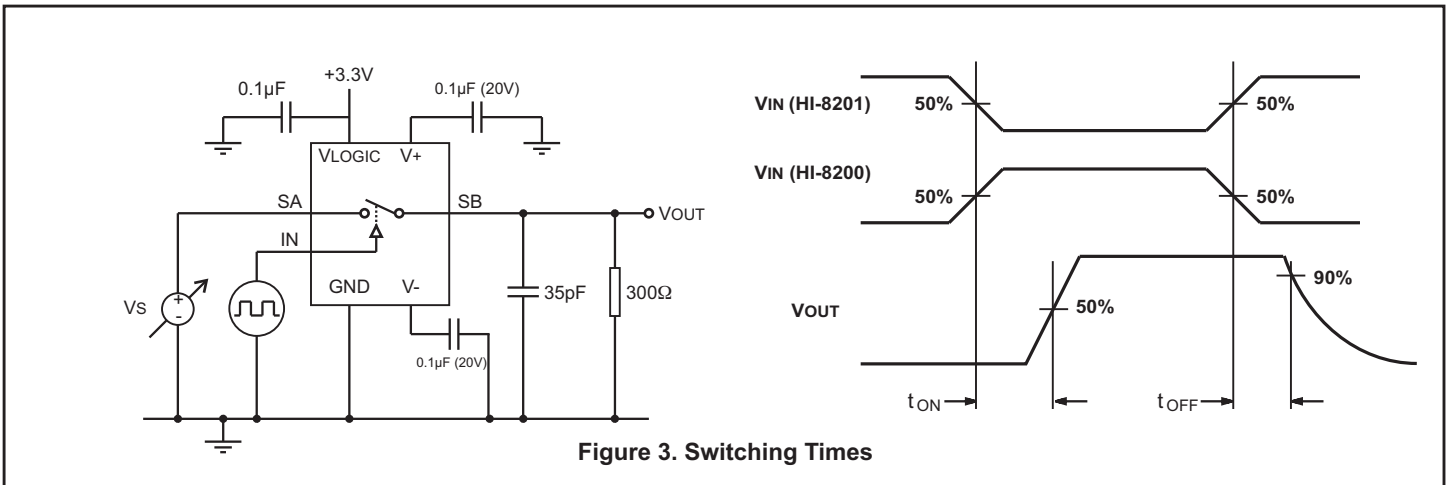
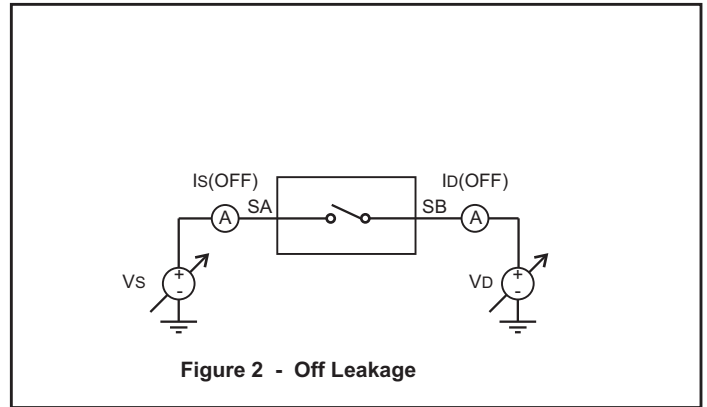
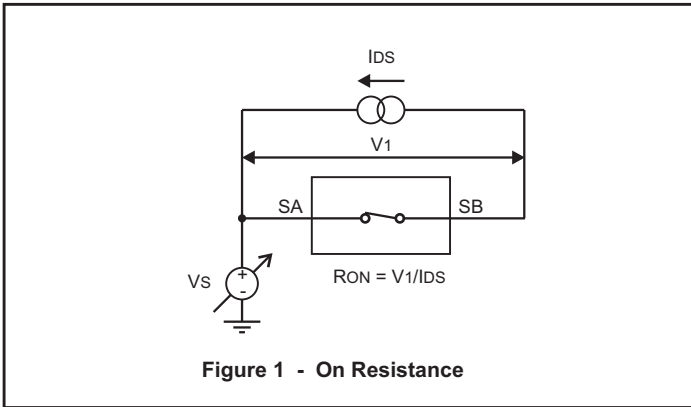

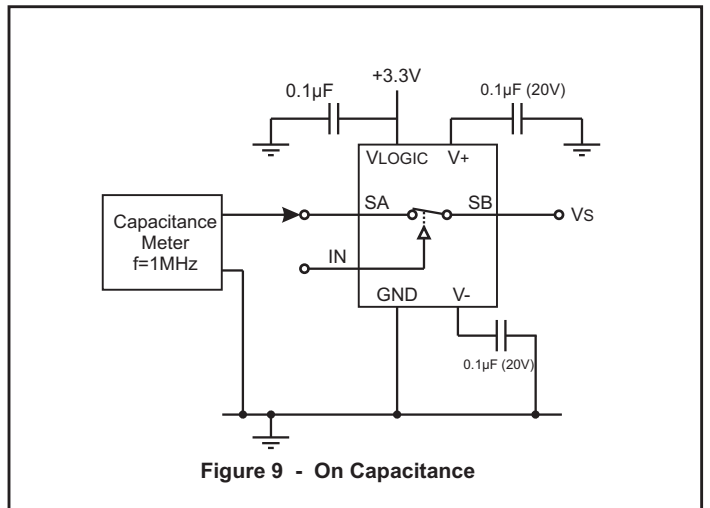
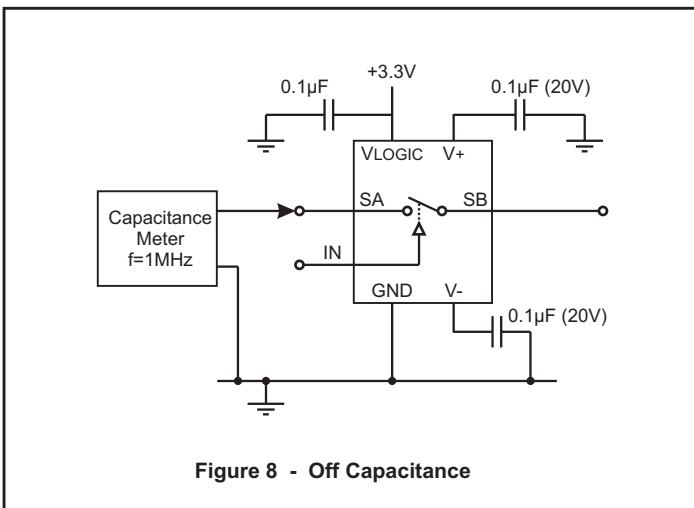
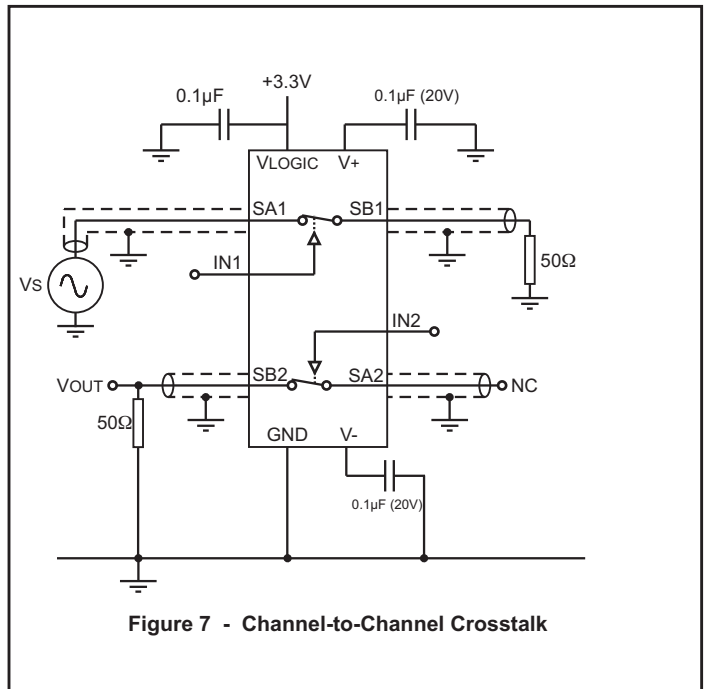
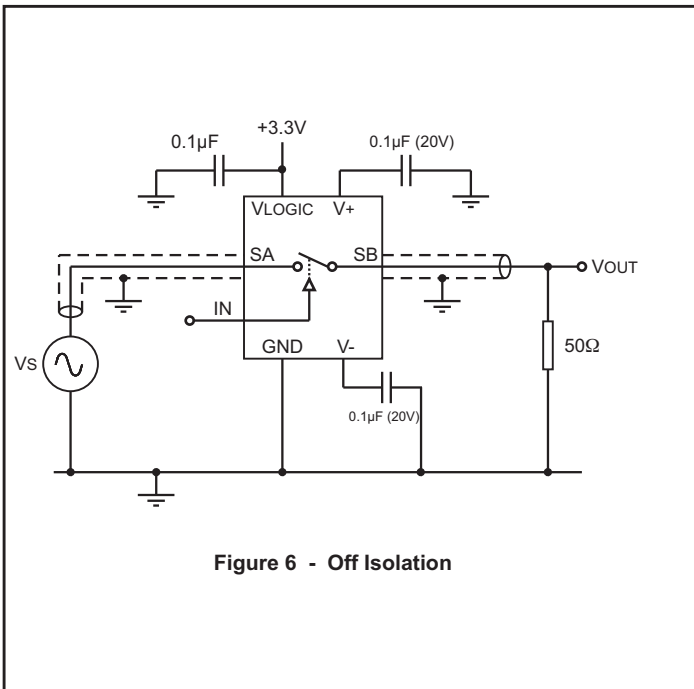
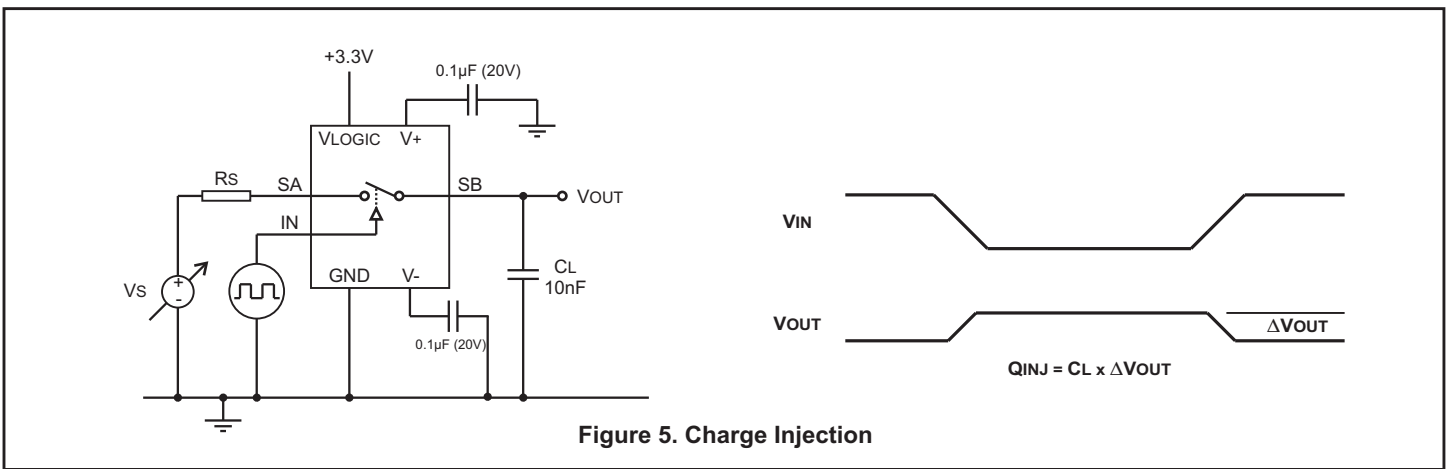

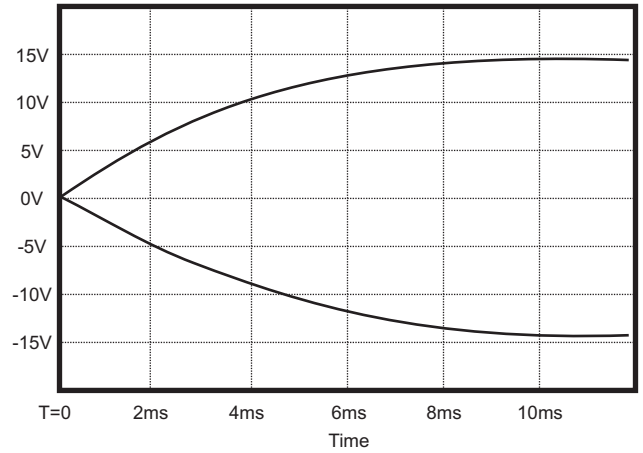
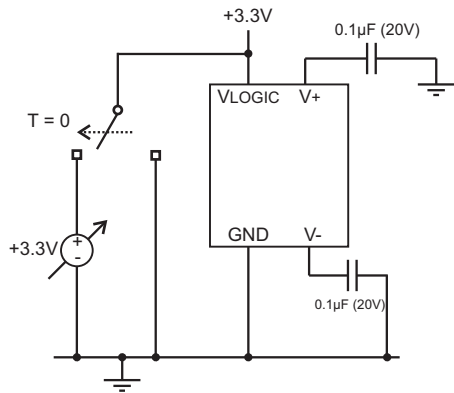
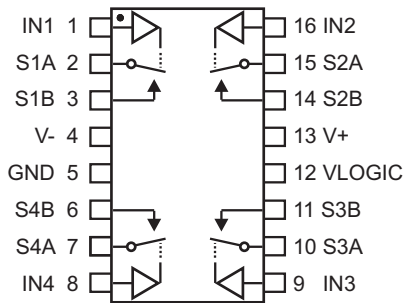

Figure 10. Charge Pump Power On

## Additional package configurations



HI-8200CRH  
16-Pin CERDIP package

**ORDERING INFORMATION**

**HI - 820x PS H F**

PART NUMBER	LEAD FINISH
F	100% Matte Tin (Pb-free, RoHS compliant)

PART NUMBER	PACKAGE DESCRIPTION
PS	20 PIN PLASTIC TSSOP (20HS): -55°C to +175°C.

PART NUMBER	FUNCTION
8200	QUAD SWITCH, NORMALLY OPEN
8201	QUAD SWITCH, NORMALLY CLOSED
8202	QUAD SWITCH, TWO NORMALLY OPEN, TWO NORMALLY CLOSED

**HI - 820x CR H**

PART NUMBER	PACKAGE DESCRIPTION
CR	16 PIN CERDIP (16D) <b>not available Pb-free</b> : -55°C to +200°C.

PART NUMBER	FUNCTION
8200	QUAD SWITCH, NORMALLY OPEN
8201	QUAD SWITCH, NORMALLY CLOSED
8202	QUAD SWITCH, TWO NORMALLY OPEN, TWO NORMALLY CLOSED

## REVISION HISTORY

---

P/N	Rev	Date	Description of Change
DS8200H	New	10/18/12	Initial Release
	A	04/19/16	Add leakage spec for power on condition. Remove typical value at 125C.

---



**20-PIN PLASTIC TSSOP**

*inches (millimeters)*

Package Type: 20HS

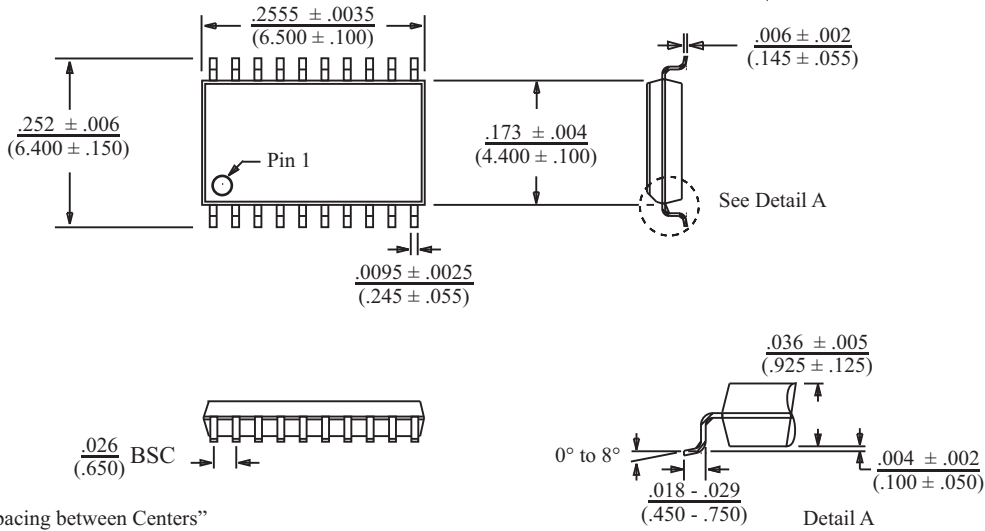

BSC = "Basic Spacing between Centers" is theoretical true position dimension and has no tolerance. (JEDEC Standard 95)

**16-PIN CERDIP**

*inches (millimeters)*

Package Type: 16D

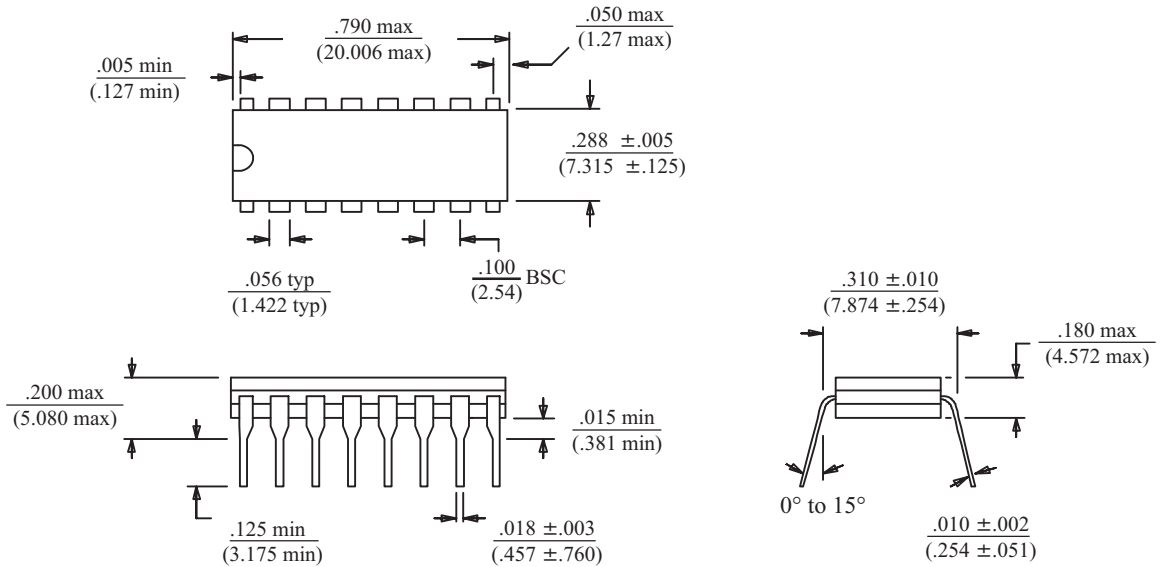

BSC = "Basic Spacing between Centers" is theoretical true position dimension and has no tolerance. (JEDEC Standard 95)