

August 2013

1 Introduction

1.1 Conventional MIL-STD-1553

Conventional MIL-STD-1553B defines a 1 Mb/sec serial data bus. It features a dual redundant balanced line physical layer, a (differential) network interface, half-duplex command/response protocol, and a single bus controller (BC) managing up to 31 remote terminals (RTs). A single bus consists of a wire pair with 70–85 Ω impedance at 1 MHz. The bus is terminated at each end using a resistance matching the bus characteristic impedance, usually 78 Ω . Each terminal (RT, BC, or Monitor) connects to the bus through a stub cable, the same type used in the bus itself. MIL-STD-1553B defines two ways of coupling the stubs to the bus: transformer coupling and direct coupling. Individual terminals are distributed along the bus cable, comprising the conventional MIL-STD-1553B multi-drop bus configuration.

Here is a conventional 1 Mb/sec MIL-STD-1553B network:

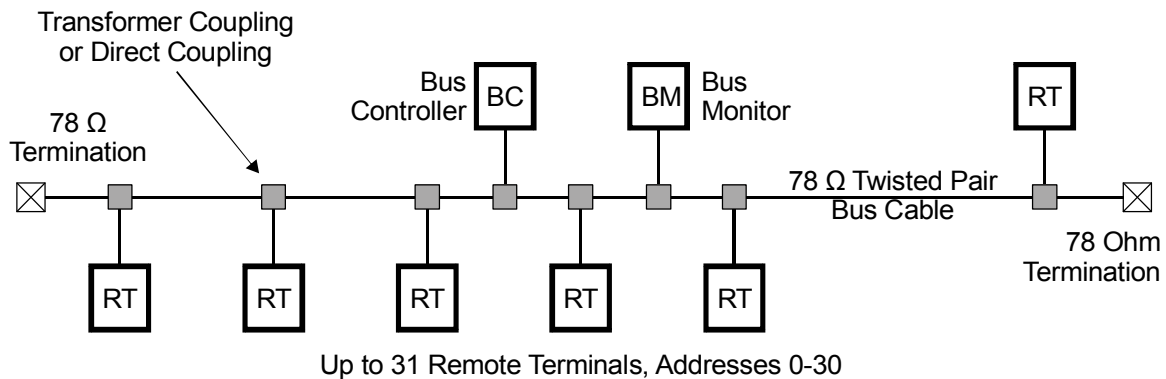

This document assumes the reader has working knowledge of conventional 1 Mb/sec MIL-STD-1553B. If the reader is unfamiliar with that Standard, comparisons with MIL-STD-1553 in the following descriptive text will not make much sense. For simplicity, redundant buses are not shown in this document.

1.2 Enhanced Bit Rate Derivatives of MIL-STD-1553

This application note describes high-speed 10 Mb/sec serial communication methods derived from the conventional multi-drop MIL-STD-1553B shown above. The Holt HI-6140 high-speed terminal is designed to operate as a Bus Controller, as a single Remote Terminal or as a Bus Monitor. Each interface between the HI-6140 and RS-485 requires an external RS-485 transceiver. The Holt HI-4853 slew-rate controlled RS-485 transceiver is ideal for such applications.

The HI-6140 can be used in a multi-drop network configuration closely resembling the conventional 1 MB/sec MIL-STD-1553 network shown above. Shown with greater detail on the next page, the multi-drop network configuration is a conventional RS-485 implementation, but not compatible with any known avionics data bus standard. In the following diagram, one HI-6140 is used in each terminal, configured as either Bus Controller or Remote Terminal. Each terminal connects to the twisted-pair cable in "direct-coupled" manner. At each end, the bus run is resistively terminated. The RS-485 transceiver selected has suitable rise/fall time for the transmission bit rate. Data rate determines maximum bus length. Driver rise/fall time determines maximum stub length. Load capacitance and cable capacitance determine the minimum node spacing to avoid distortion at receiver inputs. Refer to the excellent references on RS-485 design, at the end of this document.

When configured as shown below, the HI-6140 readily handles BC, RT and bus monitor operation. An experimental test setup using HI-6140 operated at 10 Mb/sec data rates for 100 meter distances. Lower data rates permit longer bus lengths. This scheme even handles RT to RT commands, which are disallowed for SAE Aerospace Standard SAE AS5652 (see below).

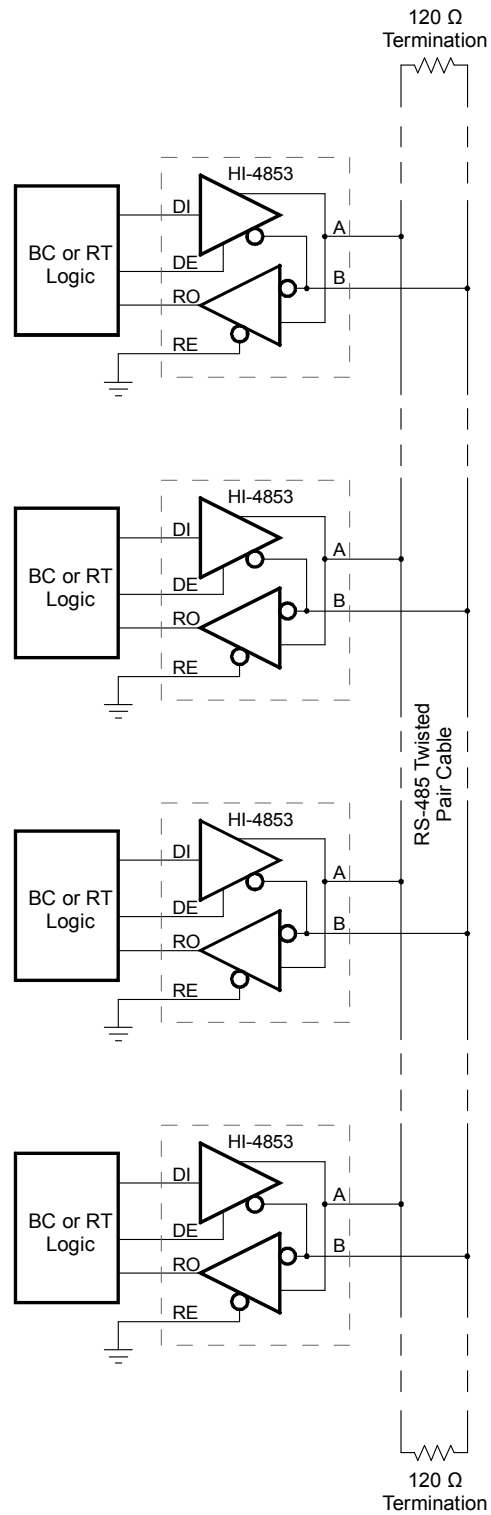

Conventional 10 MB/sec RS-485 multi-drop bus similar to single-cable MIL-STD-1553.
 No known network standard applies this approach, but it is functional when
 each "BC or RT Logic" represents a HI-6140 protocol IC.

2 SAE Aerospace Standard AS5652 for MMSI

The primary focus of this document is the SAE Aerospace Standard AS5652 also known as the “Miniature Munitions Store Interface Standard.” SAE Aerospace Standard AS5652 was developed in conjunction with the “Miniature Munitions Store Interface Standard” (MMSI), at the request of the United States Air Force. Standard AS5652 defines a 10 Mb/sec network configuration using the MIL-STD-1553B Notice II protocol, but using a different physical architecture. Instead of the multi-drop approach with terminals distributed along the length of a twisted-pair cable, the MMSI network consists of a centralized Bus Controller with logical hub, connected to individual Remote Terminals using a dedicated 120 ohm twisted pair cable (or “hub-RT link”) for each RT. The electrical characteristics of each hub-RT link are defined by Telecommunications Industry Association standard TIA-485A (also known by its old name, RS-485). The star-connected network topology and half-duplex master-slave communications protocol are defined by AS5652 (MMSI). RS-485 transceivers provide the 10 Mb/sec physical layer between the Logical Hub and each RT, as shown in the following simplified diagram.

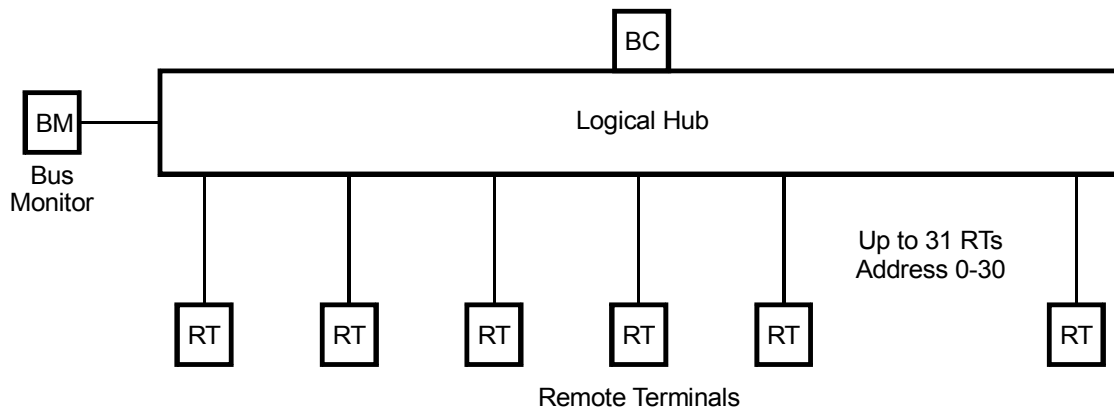

The terminal operating as Bus Controller is responsible for sending data bus commands, participating in data transfers, receiving status responses, and monitoring system status as defined in the AS5652 Standard. A Remote Terminal operates only in response to valid commands received from the Bus Controller. The RT only accepts command words as valid when they contain a terminal address matching its assigned RT address, or broadcast terminal address 31 when the RT supports broadcast commands. Further, the command word must begin with a properly-encoded Command Sync, and must contain 16 properly-encoded Manchester II data bits, plus a parity bit expressing correct “odd parity”.

SAE AS5652 defines three operating modes for Logical Hub communication with the attached RTs: Spec Mode, Switch Mode and Link Mode. Remote Terminals based on the HI-6140 protocol IC are compatible with all three modes without modification or prior operating mode selection.

An AS5652 Bus Controller based on the HI-6140 makes use of design features in the device which simplify the Logical Hub interface. One configuration option enables a 5-bit parallel RT address output from the BC logic. The 5-bit parallel address output is updated just before each serial Command Word is issued by the Bus Controller; the Logical Hub uses the register address values for routing BC Command Words to Remote Terminals. The 5-bit RT address output is used quite differently for the three data bus operational modes described next.

2.1 AS5652 Spec Mode

In Spec Mode, data bus operation closely mimics behavior of the conventional MIL-STD-1553 bus. The BC transmits commands to all RTs simultaneously through the Logical Hub (unless an RT line has its RT Link Shutdown enabled). There is no physical mapping of individual Logical Hub-RT links to particular RT addresses. Each RT derives its terminal address from an external mechanism and only accepts or responds to command words containing its assigned RT address or broadcast address 31. In AS5652 Spec Mode, the BC Logical Hub does not enable visibility of RT transmissions to other RTs. A difference from conventional MIL-STD-1553B, standard SAE AS5652 disallows RT to RT messages.

In the diagram below, the bus runs in AS5652 Spec Mode. A BC command addressed to terminal RT4 simultaneously goes to all RTs. Configured for Spec Mode, the Logical Hub routes all BC Command Words to all Remote Terminals; all Hub-to-RT links are enabled. Only the RT set with matching terminal address 4 responds. The RT response is routed from the responding Hub-RT link to the BC:

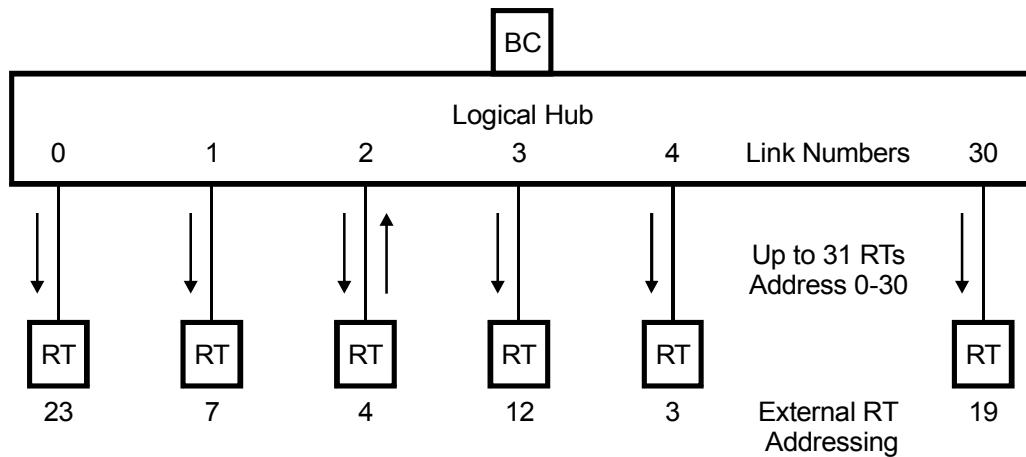

In Spec Mode, the Logical Hub does not know in advance which Hub-RT link will carry the RT response. The Logical Hub must be prepared to route a response from any RT link to the Bus Controller. In the most likely scenario, the Hub logically-ORs received data from all connected RS-485 Hub-RT transceivers.

In the other two operating modes, the Hub knows the active RT link before RT response begins.

2.2 AS5652 Switch Mode

In Switch Mode, individual Logical Hub-RT links are physically mapped to particular RT addresses. The BC sends the next-command RT address to the Logical Hub before issuing each new Command Word. The Hub routes the BC command only to the Hub-RT link associated with the RT address in the Command Word. Each RT derives its terminal address from an external mechanism and only accepts or responds to commands containing its assigned RT address or broadcast address 31. Broadcast commands to RT address 31 are transmitted to all RTs simultaneously. Like Spec Mode, the BC Logical Hub does not enable visibility of RT transmissions to other RTs since RT to RT messages are disallowed.

The bus shown below runs in AS5652 Switch Mode. A BC command addressed to RT3 goes only to the hub link associated with terminal RT3. The receiving RT responds if set for matching terminal address 3:

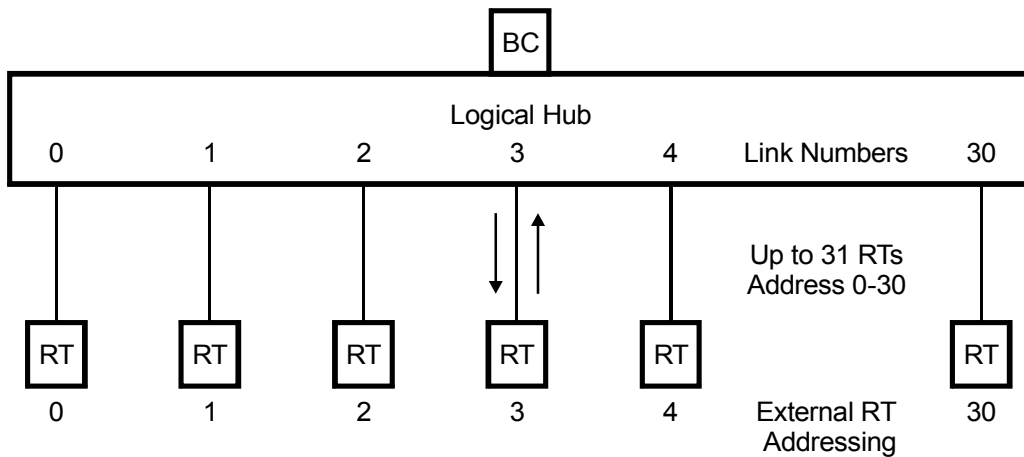

2.3 AS5652 Link Mode

Link Mode eliminates the need for external addressing at each RT. All RTs utilize default RT terminal address 0. Link Mode physically maps individual Logical Hub-RT links to particular RT physical locations. The Logical Hub knows which Hub-RT link corresponds to each RT address. The BC sends the next-command RT address to the Logical Hub before issuing each new Command Word. The Hub routes the BC command only to the Hub-RT link associated with the parallel RT address provided by the BC. Each RT only accepts or responds to command words containing RT address 0 or broadcast address 31. Broadcast commands to RT address 31 are transmitted to all RTs simultaneously. As above, the BC Logical Hub does not enable visibility of RT transmissions to other RTs since RT to RT messages are disallowed.

The bus shown below runs in AS5652 Link Mode. The BC first updates the 5-bit RT address output with the target terminal address, for example RT3. The BC then issues the Command Word for RT3 which always contains the embedded address terminal RT0. (Thus the parallel target address output by the BC, i.e. 3, differs from the embedded address in the command, except when RT0 is the target address.) The Logical Hub immediately activates the Hub-RT link associated with the RT3 physical location; the following BC Command Word is routed only to the Hub-RT link mapped to the RT3 physical location. The receiving RT on Hub-RT link 3 responds if assigned the default terminal address 0:

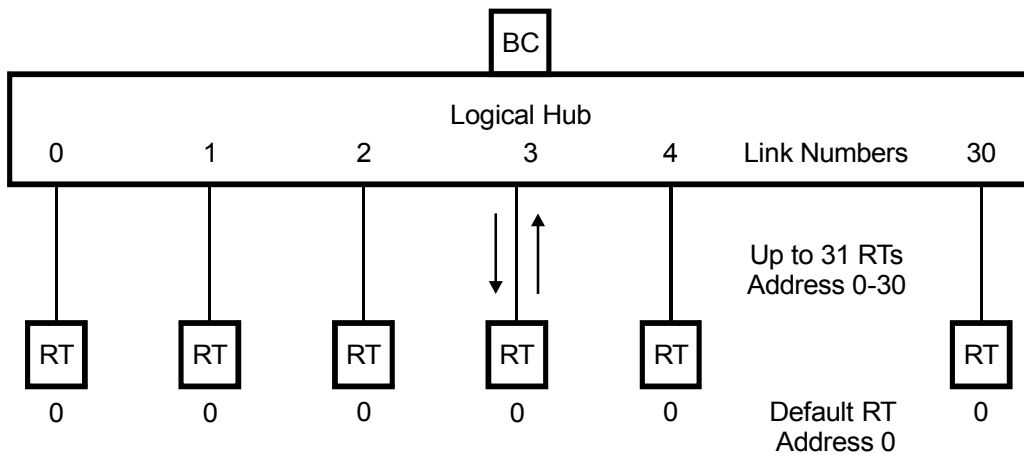

Remote terminals based on the Holt HI-6140 protocol chip and HI-4853 transceiver for RS-485 can perform all three modes defined in SAE AS5652: Spec Mode, Switch Mode and Link Mode.

3 Bus Controller and Logical Hub Design for SAE AS5652

The HI-6140 protocol IC has a logic level signal interface to the hub, using two outputs (Transmit Enable and Transmit Data) and one input (Receive Data). Manchester II logical encoding and decoding occur within the BC HI-6140. Separate RS-485 transceivers in the Logical Hub connect to each Hub-RT link; the Hub selectively routes logic-level signals between Hub-RT links and the Bus Controller based on a 5-bit parallel RT address output from the HI-6140 BC state machine. The 5-bit parallel RT address output is updated at least 250us before the BC issues a new Command Word. The parallel address value is static beyond the ACTIVE output signal going low, and remains static until the BC is ready to transmit the next Command Word.

Here is a SAE AS5652 hardware concept using HI-6140 protocol devices for both BC and RTs, and HI-4853 transceivers for each RS-485 Hub-RT link. The signal interface consists of 3.3V logic level signals connecting each HI-6140 to its RS-485 transceiver:

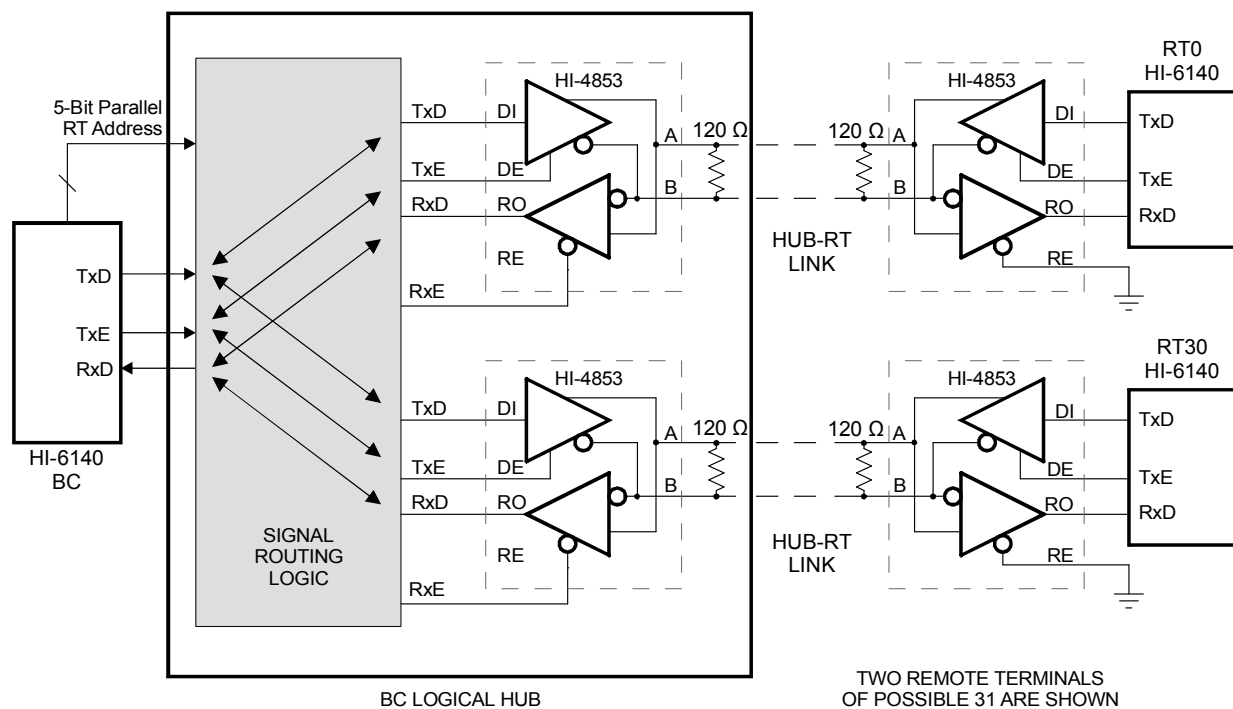

Backing off on the signal interface detail and showing other BC and Logical Hub considerations results in the diagram below. The 5-bit parallel RT address output is enabled when the Bus Controller HI-6140 is configured with register 0x4D bit 3 set to logic 1.

AS5652 BC Logical Hub Star Architecture

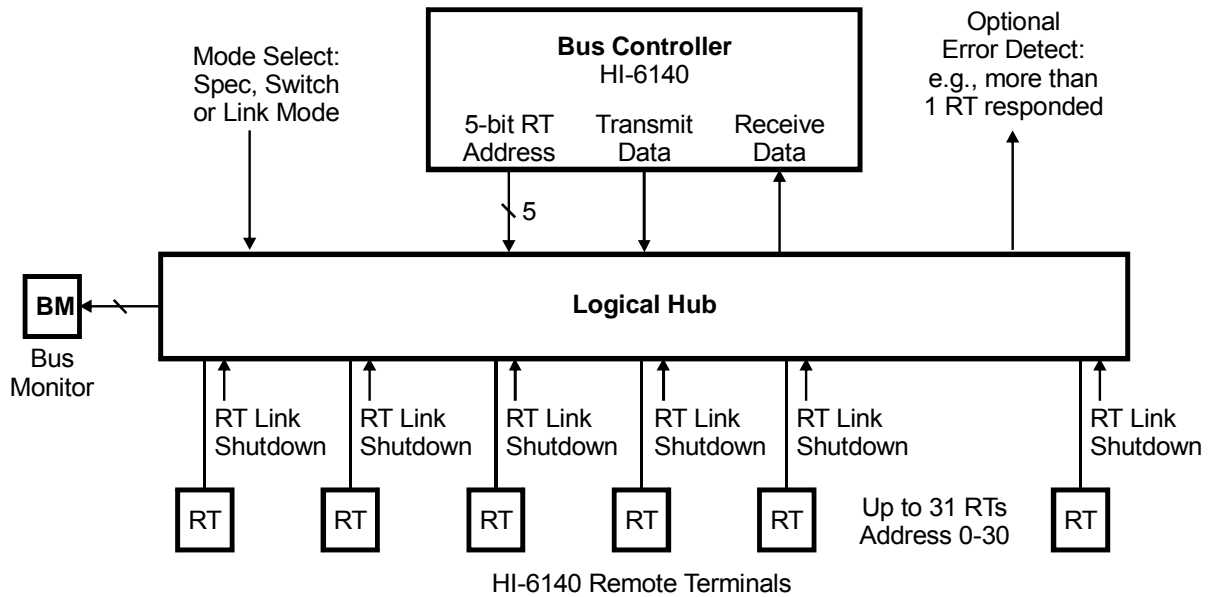

The unique addressing scheme for Link Mode is selected when register 0x4D bit 4 is set to logic 1. So configured, the 5-bit parallel RT address output specifies the RT address derived from the BC Instruction List, but each Command Word issued by the Bus Controller contains embedded RT address 00000 at Command Word bits 15:11. Please refer to the HI-6130 data sheet for BC Instruction List setup.

For use in SAE AS5652 Bus Controllers, HI-6140 error detection logic implements the following timing differences from conventional MIL-STD-1553B, measured from BC Command Word mid-parity to RT Status Word mid-sync:

Minimum Inter-Message Gap = 1 μ s.	(versus 4 μ s for MIL-STD-1553B)
Minimum No Response Timeout = 8 μ s.	(versus 12 μ s for MIL-STD-1553B)
RT response must begin within 400 ns to 4 μ s	(versus 4 to 12 μ s for MIL-STD-1553B)

SAE AS5652 has several protocol differences, compared to conventional MIL-STD-1553B. The following commands are disallowed in AS5652:

- i. All RT to RT messages are undefined
- ii. Transmit mode code 0 command, "Dynamic Bus Control"
- iii. Transmit mode code 4 command, "Transmitter Shutdown"
- iv. Transmit mode code 5 command, "Override Transmitter Shutdown"
- v. Receive mode code 20 command, "Selected Transmitter Shutdown"
- vi. Receive mode code 21 command, "Override Selected Transmitter Shutdown"

HI-6140 logic circuitry does not prevent the BC from issuing these disallowed commands. To prevent their transmission, the BC Message Blocks configured in device RAM should not include these commands. So configured, it is impossible for the Bus Controller to issue the disallowed commands.

A Bus Monitor based on the HI-6140 would be connected to monitor the BC to Logical Hub signal interface. This would work adequately for AS5652 Switch Mode or Spec Mode, but the unusual RT0 addressing for AS5652 Link Mode requires logic outside the HI-6140 to capture the 5-bit parallel RT address value and merge that information into the automatically logged data recording. An in depth description of Bus Monitor design is beyond the scope of this document.

4 Holt Reference Designs

For enhanced bit rate 1553 applications, Holt offers two development kits based on the HI-6140 device:

The first kit, ADK-6140BC, is specifically designed for star-topology AS5652 MMSI Bus Controller applications. This kit consists of one circuit board with a HI-6140 EBR-1553 protocol IC, a Verilog configured CPLD acting as logical hub and RS-485 transceivers for 4 of the possible 31 hub-RT links. A detachable ARM Cortex M3 MCU board provides the necessary programmability for various applications. The example logical hub implements MMSI Spec, Switch and Link address modes. The kit includes ARM software projects written in ANSI C and an installation CD for IAR Systems Embedded Workbench® for ARM (32KB KickStart edition). This integrated development environment (IDE) compiles provided C- language projects for various terminal functions.

The second kit, ADK-6140RT, supports generic high-speed 1553 protocols using an RS-485 physical layer. This kit consists of one circuit board with HI-6140 and RS-485 transceiver; a detachable ARM Cortex M3 MCU board provides the necessary programmability for various applications. This kit supports AS5652 MMSI Remote Terminals (but not Bus Controller). Using different software, both Bus Controller and Remote Terminals are supported for single-cable multi-drop enhanced bit rate 1553, as described at the start of this document. This kit also includes an installation CD for IAR Systems Embedded Workbench® for ARM (32KB KickStart edition), enabling editing, debug and compiling of the included C- language projects.

5 References

Aircraft Internal Time Division Command/Response Multiplex Data Bus, Military Standard MIL-STD-1553B Notice 2, (1986).

10 Megabit/sec Network Configuration, Digital Time Division Command/Response Multiplex Data Bus, SAE Aerospace Standard AS5652, (2005).

The RS-485 Design Guide, Texas Instruments publication SLLA272B.

REVISION HISTORY

P/N	Rev	Date	Description of Change
AN-6140	NEW	08/12/13	Initial Release